

SLANT

TABLE LEG



USER GUIDE

TABLE OF CONTENTS

| | |
|------------------------------|-----|
| Parts Diagram | 4 |
| 42", 36", 29" Legs | 4 |
| Safety Information | 5 |
| Assembly Instructions | 6-7 |

STANDARDS & CERTIFICATIONS

Meets 2014 BIFMA standards.

WARRANTY

Contact your sales representative for warranty information.

PARTS DIAGRAM

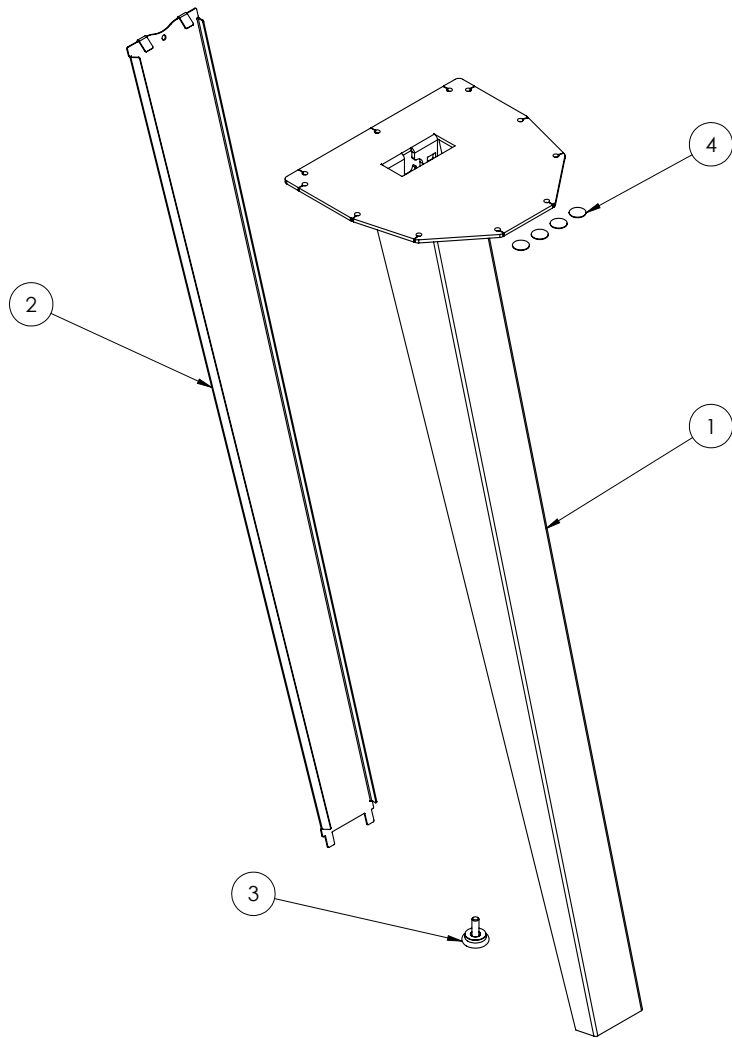

| PARTS | Qty/Package |
|----------------|--------------------|
| 1. Leg | 1 |
| 2. Cover Panel | 1 |
| 3. Glide Foot | 1 |
| 4. Felt Pads | 4 |

SAFETY INFORMATION

IMPORTANT SAFETY INSTRUCTIONS *Save these instructions.*

INSTALL ONLY APPROVED WORK SURFACES

This table system does not include a work surface (desktop). Desktop dimensions for four-leg configurations are not to exceed 60" diameter. If you are unsure if your preferred work surface meets specifications, contact customer service.

DO NOT OVERLOAD DESK

To prevent table from tipping or collapsing, make sure the desk frame is not overloaded by the weight of tabletop and objects on table. Evenly distribute load; excess loads near edges can reduce stability and cause table to tip over.

- Do not exceed maximum load (including weight of desktop) of 200 lb (91Kg)
- Do not sit or stand on table

USE CARE WHEN MOVING TABLE

- Remove all objects and mounted accessories from the table before moving
- Clear objects and equipment from table before rolling to reduce the risk of tipping over

ASSEMBLY INSTRUCTIONS

The assembly of the table frame to be made in accordance with this manual. Changes to the table frame or improper use may affect the safety, function, and life of your product.

This manual applies to the following table legs: 29", 36" and 42".

ILLUSTRATION A

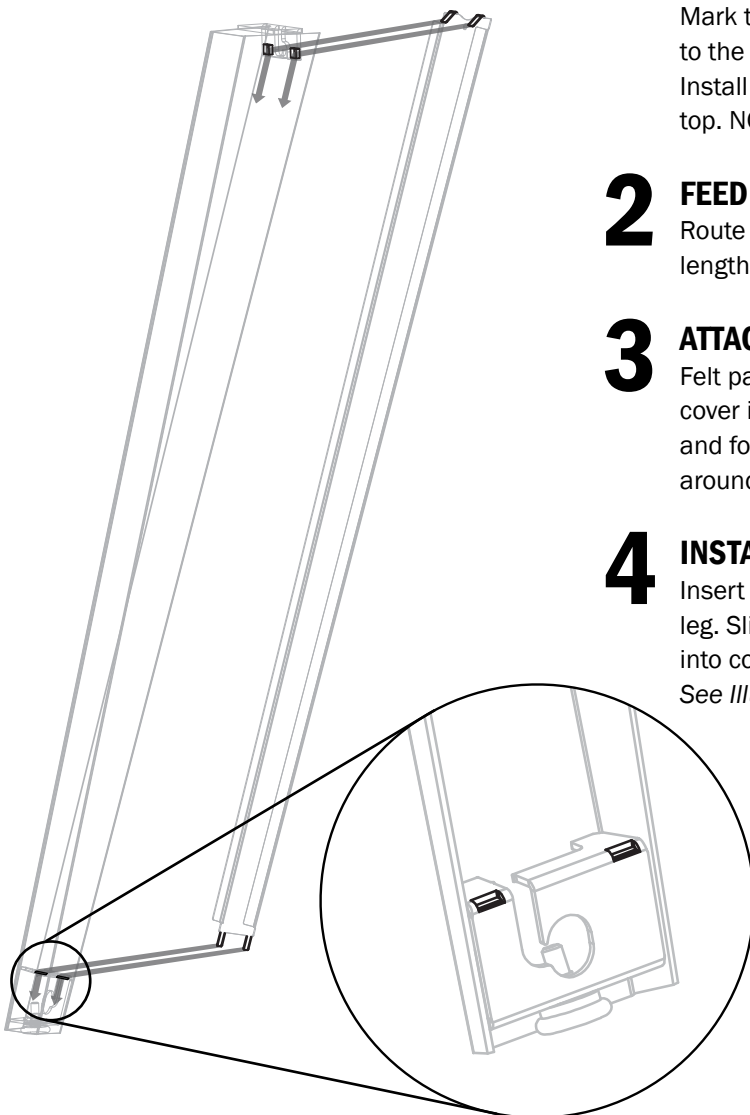

1 INSTALL LEG ASSEMBLY TO THE TABLE TOP

See Illustrations C–E to choose your preferred configuration. Mark the locations of the pilot holes. Drill the pilot holes to the size recommended by the table top manufacturer. Install the screws through the mounting plate into the table top. NOTE: The holes in the mounting plate are .13 in

2 FEED CORD THROUGH LEG

Route the cord into top and bottom hooks. Gather as much length as desired in the space between the two hooks.

3 ATTACH FELT PADS TO TABS

Felt pads will eliminate any rattle that may occur where cover is attached to leg. At top of leg, place pads into slots and fold down to overlap. See Illustration B. Wrap pads around each of the lower tabs on the cover.

4 INSTALL COVER PANEL TO LEG

Insert tabs on top of cover panel into corresponding slots of leg. Slide cover panel downward so that bottom tabs insert into corresponding slots at the bottom of the foot.

See Illustration A

ILLUSTRATION B

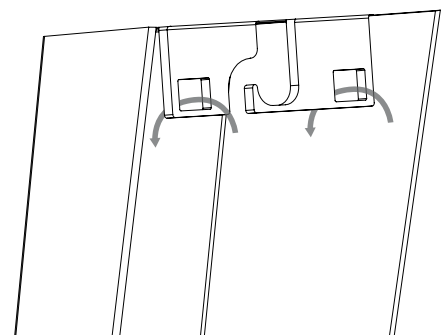
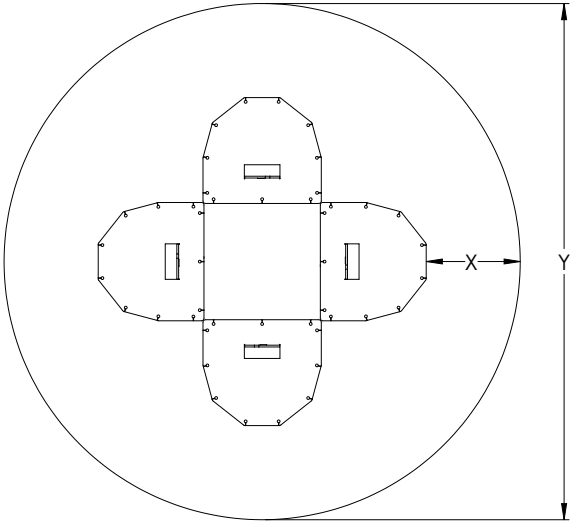

ILLUSTRATION C



ROUND TOP CENTER CONFIGURATION

| | | |
|---------------------------------|---------------------------------|---------------------------------|
| 42" | 36" | 29" |
| X: 8.75" | X: 6.8125" | X: 4.75" |
| Y: 48" (minimum table top size) | Y: 46" (minimum table top size) | Y: 40" (minimum table top size) |

ILLUSTRATION D

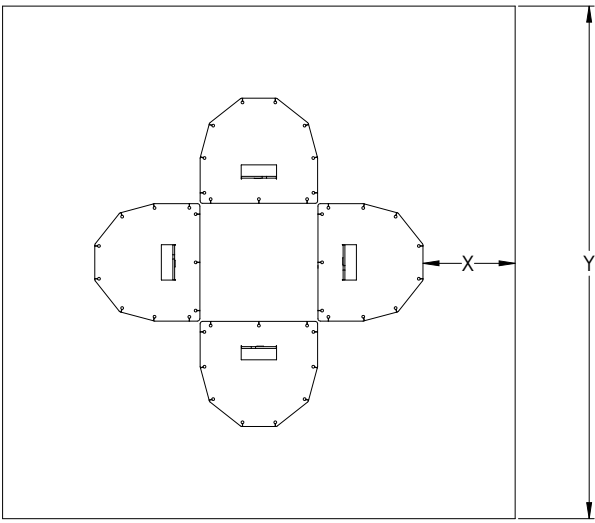

SQUARE TOP CENTER CONFIGURATION

| | | |
|---------------------------------|---------------------------------|---------------------------------|
| 42" | 36" | 29" |
| X: 8.75" | X: 6.8125" | X: 4.75" |
| Y: 48" (minimum table top size) | Y: 46" (minimum table top size) | Y: 40" (minimum table top size) |

ILLUSTRATION E

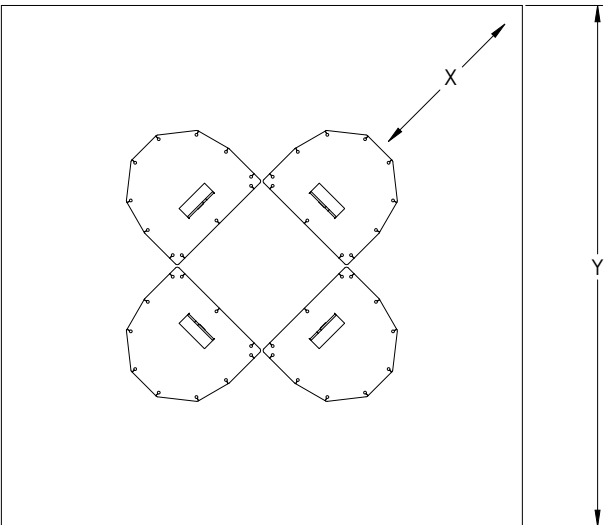

SQUARE TOP CORNER CONFIGURATION

| | | |
|-------------------------------|-------------------------------|-------------------------------|
| 42" | 36" | 29" |
| X: 11.5" | X: 9.5" | X: 7.375" |
| Y: 38" minimum table top size | Y: 36" minimum table top size | Y: 32" minimum table top size |

Maximum tabletop diameter is 60".

If you have any difficulty assembling this unit, or need to order replacement parts, please contact our Customer Service department. Use the parts diagram on page 4 as a reference.

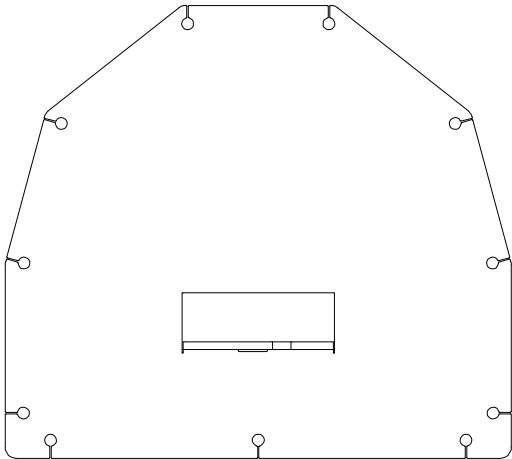

MOUNTING PLATE

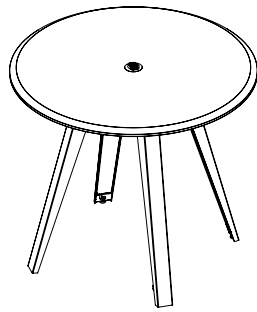

SLANT

USER GUIDE